

WALL ART: FLORAL SCULPTURE

Tools Required to Make this Design:

Scrolling: Mk 1/2 or Mk 2/2H or Mk 2/3 Former
 Punching: Practical or Master Punch/Shear (or XL5+ Power Bender fitted with 3mm punch block & pin - or use 5mm holes but 5mm rivets will be required*)
 Riveting: Practical or Master RBR (or XL5+ Power Bender)
 Rolling: Practical or Master RBR (or XL5+ Power Bender - radius may need to be altered)
 Cutting: Practical or Master Punch/Shear (or XL5+ Power Bender)

1 Main Stem 920mm (x 1)

COMPONENT 1

It is recommended with all steel lengths, you first remove any excess oil, grease or scale with a cloth or abrasive paper.

Take the length of 920mm (3') 15 x 3mm steel, trim all the corners for a better finish then, using a fine tip marker or pencil, mark the centre C1 as shown in Component 1 overleaf.

Setting up the R/B/R tool for rolling, firstly roll from one end to the centre mark 'C1', then turn the steel over and roll from the other end up to 'C1' to form an 'S' shape, using Diagram 1 overleaf as a rough guide. Remember, you can always increase or decrease the curvature by pulling the steel back in the R/B/R tool and rolling it further or alternatively, putting the steel in the tool the opposite way round to "flatten out" the curve.

2a Branches 300mm (x 3)

COMPONENT 2a

Take one length of 920mm (3') 12 x 2mm steel, mark at intervals of 300mm and cut the three pieces, using the Punch/Shear tool. Trim all the corners then, on two of the lengths, mark at the scroll point 'S1' 100mm from one end as shown in Component 2a overleaf. Now scroll up to this mark using the Mk 1/2, Mk 2/2H or the Mk 2/3 Former. Do this on both marked lengths.

Next, using Diagram 1 as a guide, roll all the three cut lengths as illustrated. This does not need to be precise nor do the 3 curves need to be identical.

2b Large Branch 450mm (x 1)

COMPONENT 2b

Take another length of 920mm (3') 12 x 2mm steel, mark at 450mm, cut and trim all the corners. Mark at the scroll point 'S2' 100mm from one end as shown in Component 2b overleaf. Now scroll up to this mark using the Mk 1/2, Mk 2/2H or the Mk 2/3 Former as on the two shorter lengths.

Now, using Diagram 1 as a guide, roll the cut length to form the longer of the bottom branches.

3 Leaves/Large Flower 180mm (x 10)

COMPONENT 3

Take two lengths of 920mm (3') 10 x 1.6mm steel, mark five times at intervals of 180mm on each length, cut, trim the corners and finally mark the centre 'C1' on all ten pieces.

Leaves: Take four of these cut strips and roll each in turn in the R/B/R tool until the gap between the two ends is approx 40mm. Next, using Template 1 overleaf as a guide, bend each one at the centre 'C1' until the ends meet, thus forming a leaf shape.

Large Flower Petals: Repeat the above process on each of the six remaining 180mm lengths to form the Flower Petals only, this time, not bending quite so much as with the leaves but rather leaving a gap of approx 15mm. Use Template 2 as a guide.

4 Small Flower Petals 150mm (x 5)

COMPONENT 4

Take the final length of 920mm (3') 10 x 1.6mm steel, mark five times at intervals of 150mm this time, cut, trim the corners and finally mark the centre 'C1' on all five pieces.

Repeat the rolling and bending process exactly as with the Large Flower Petals on all five pieces but this time using Template 3 as a guide.

5 Alternative Design

When making the Large and Small Flower Petals, you can choose to bend the petal shapes instead of rolling them (see Diagrams 2 & 3 overleaf). To do so, use the same lengths of steel as used on the rolled petals but this time bend them into the shapes shown in Templates 4 & 5.



6 Assembly

Lay out all the completed Floral Wall Art pieces on a large work surface to match the design in Diagram 1 overleaf, at this point you may wish to make fine adjustments to bends or curves either by putting them back in the R/B/R tool or manipulating them by hand, in particular ensure all the petals fit snugly together to form each complete flower head. When happy, start by marking all the punch and rivet points on the flower heads. Next, using the Punch/Shear tool, set the platform for punching in the centre of the small 10 x 1.6mm material (using a small offcut). Once set, this will be used to punch ALL the material - this is so the finished design will sit flush to the wall when mounted. It is therefore important you check all the pieces are the right way round before punching!

With the platform set, punch at all the marked points on all the petals plus fixing point at the top of the Main Stem. Repeat this for the Small Flower Petal and join it to the 300mm branch (without the scroll).

Next rivet the Small Flower Branch to the Main Stem. Then rivet the Leaves to the Main Stem starting with the highest Leaf and working your way down the Main Stem. Finally rivet the remaining Branches to the Main Stem. By producing variations of this flower pattern, you can build up larger floral sculptures which can be wallmounted or free standing if fixed into the ground.



Design Pack WALL ART: FLORAL SCULPTURE

metalcraft™

DIFFICULTY RATING:

EASY	✓
STRAIGHTFORWARD	
MORE COMPLEX	

Finishing
 The finished item can now be painted in a wide variety of finishes (smooth, satin, hammer and metallic) either by aerosol or by brush application. Powder coating and plastic dip finishes can also be applied but these type of finishes are more for commercial/industrial scale finishing.
 However, even with aerosol or paint finish you can make your finished item look professional. In this case we used paints from the Plastikote and Hammerite ranges - available from most DIY and Painting/Decorating outlets. For best results, always follow instructions on the tin and make sure the metal is free of all scale, dirt, grease or rust.

Design Pack: WALL ART: FLORAL SCULPTURE - DESIGN SHEET

Main Stem x 1

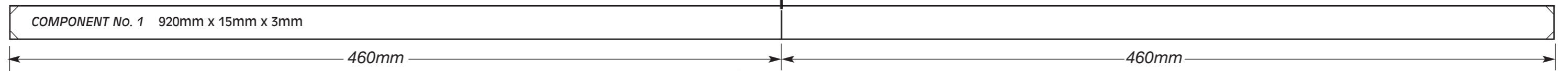

Branches x 3

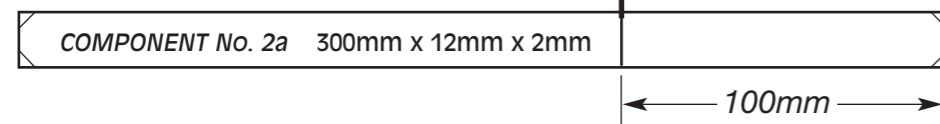

Large Branch x 1

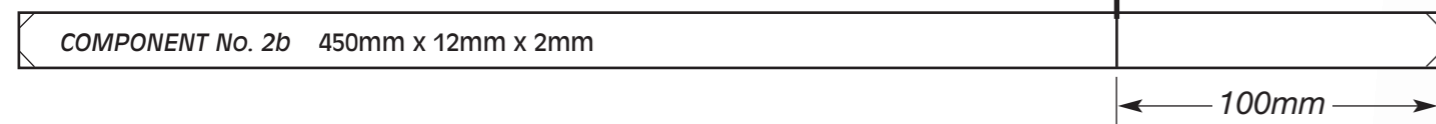

Leaves/Large Flower x 10

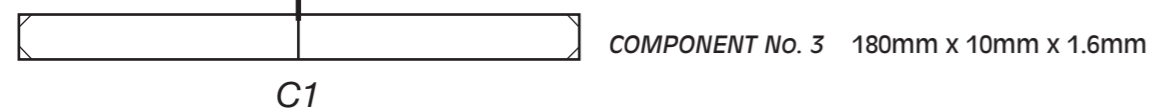

Small Flower x 5



Leaves x 4

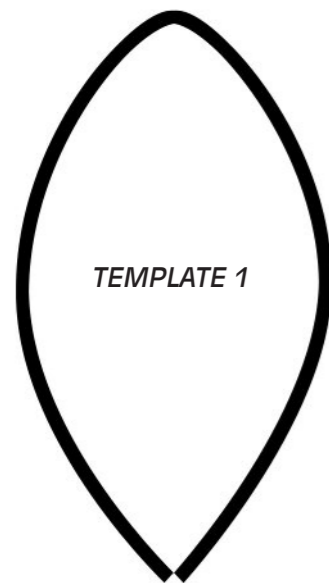

Large Flower x 6

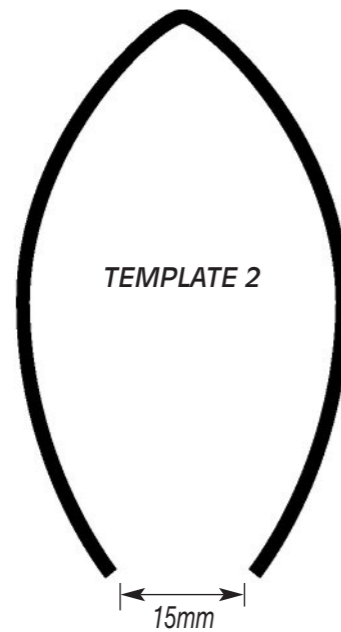

Small Flower x 5

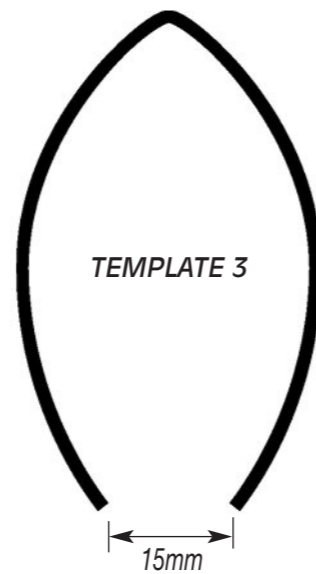

List of Materials Required:

- 1 x 920mm (ft) Lengths of 15mm x 3mm Steel Strip [Re-Order Ref: MC037]
- 2 x 920mm (ft) Lengths of 12mm x 2mm Steel Strip [Re-Order Ref: MC034]
- 3 x 920mm (ft) Lengths of 10mm x 1.6mm Steel Strip [Re-Order Ref: MC031]
- 8 x 3mm Rivets [Re-Order Ref: MC051L]

DIAGRAM 1

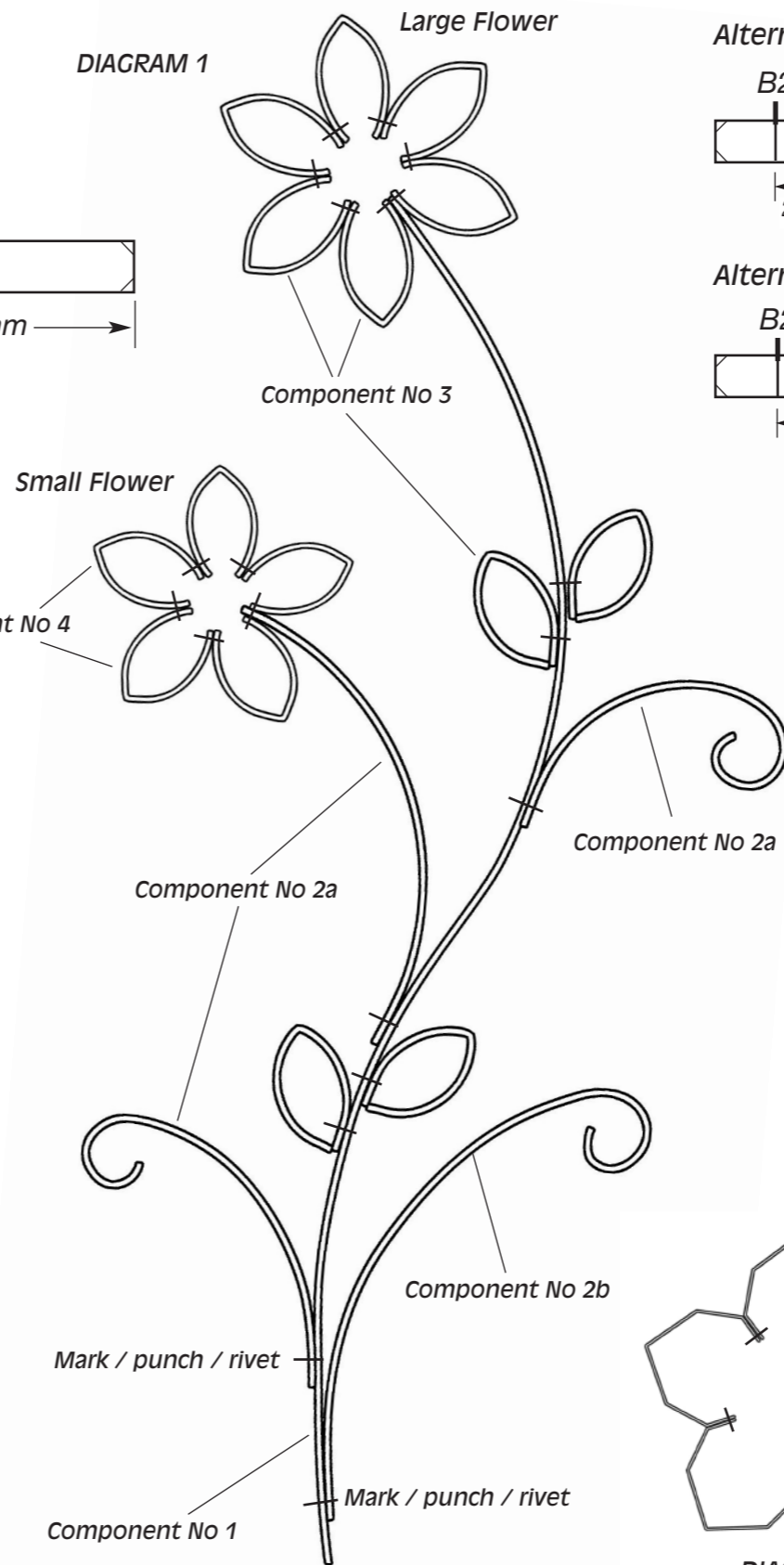

Alternative Small Flower x 5

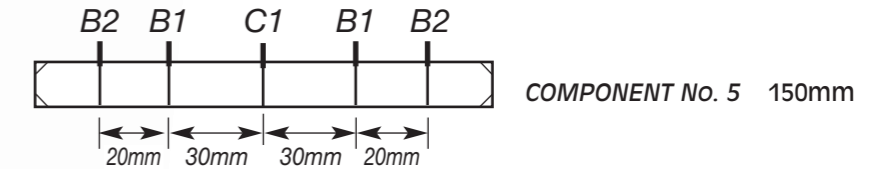

Alternative Large Flower x 5

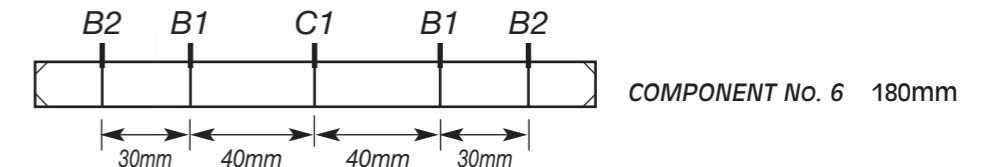

Alternative Small Flower x 5

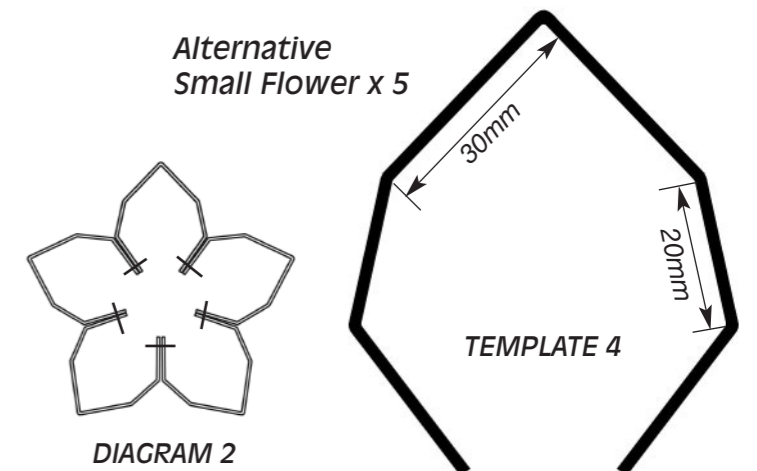

Alternative Large Flower x 6

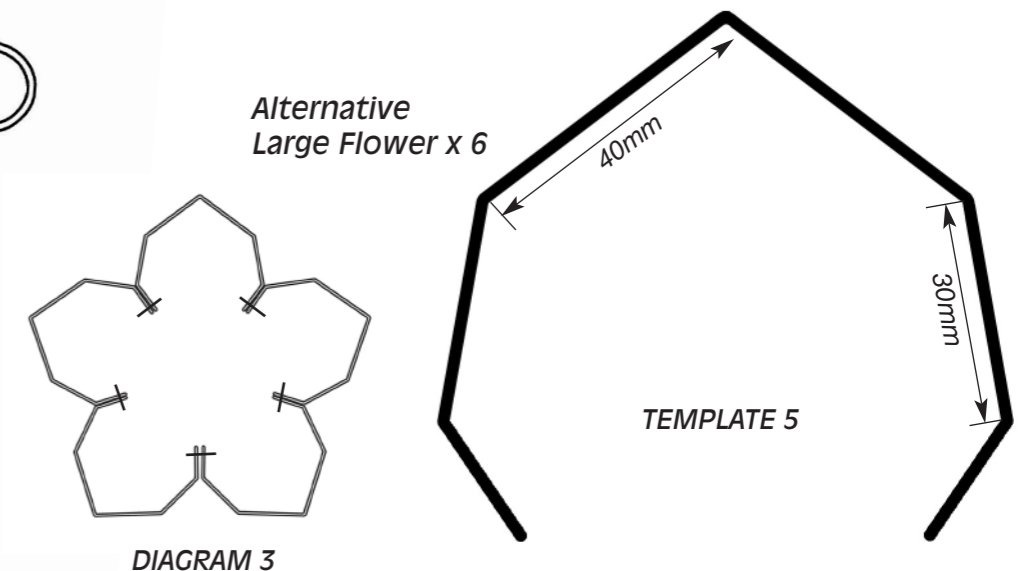

WALL ART: ABSTRACT FLORAL PATTERN

Tools Required to Make this Design:

Scrolling: Mk 2/2H or Mk 2/3 Former
 Punching: Practical or Master Punch/Shear (or XL5+ Power Bender fitted with 3mm punch block & pin)
 Riveting: Practical or Master RBR (or XL5+ Power Bender)
 Rolling: Practical or Master RBR (or XL5+ Power Bender - radius may need to be altered)
 Cutting: Practical or Master Punch/Shear (or XL5+ Power Bender)

1 Scrolls

COMPONENT 1

It is recommended with all steel lengths, you first remove any excess oil, grease or scale with a cloth or abrasive paper.

Take five lengths of 920mm (3') 12 x 2mm steel then, using the Punch/Shear tool, trim all the corners to give a better finish. Next, using the Mk 2/3 Former (or the 2/2H) create a full scroll (approx 420mm) on all five lengths, to point S1.

Next, set up the R/B/R tool for rolling and, using Tempate No. 1 as a guide, roll the scroll tails of all the five scrolls. Remember, if you over roll, you can always put it in the other way round to straighten and then start again. Because the pattern is abstract, it is not critical that the scrolls are all identical.

2 Tabs for Flowers

COMPONENT 2

With one of the offcuts of steel from Component 1, use a fine tip marker or pencil to mark eleven pieces each 25mm long. Then cut all pieces.

Next, mark in the middle of the 'tab' and approx 6mm from each end. At the central mark bend on the Practical R/B/R to 90° then, using the Practical Punch/Shear tool, punch centrally at all the 6mm marks.

3 Assembly

Using Diagram 1 as a guide, lay out the five scrolls and mark at the 5 points, R1, where the scrolls touch, plus the 6 points, R2, where additional flowers are to be attached. Punch all holes at these marked positions.

Then, starting with the R1 joints, add one of the tabs at each joint and then rivet each joint using the 10 x 3mm rivets.

Next rivet tabs at the R2 joints using the 8 x 3mm rivets so that you have 11 tabs riveted to the scrolls with all the flat faces facing upwards so that the flowers can be attached using the 6mm x 3mm nuts & bolts.

4 Finishing

The finished item can now be painted in a wide variety of finishes (smooth, satin, hammer and metallic) either by aerosol or by brush application. Powder coating and plastic dip finishes can also be applied but these type of finishes are more for commercial/industrial scale finishing.

However, even with aerosol or paint finish you can make your finished item look professional. In this case we used paints from the Plasti-kote and Hammerite ranges - available from most DIY and Painting/ Decorating outlets. For best results, always follow instructions on the tin and make sure the metal is free of all scale, dirt, grease or rust. Note - for more interesting effects, you can also use Letraset Promarker pens to achieve a wide range of colours & effects on the flower attachments.

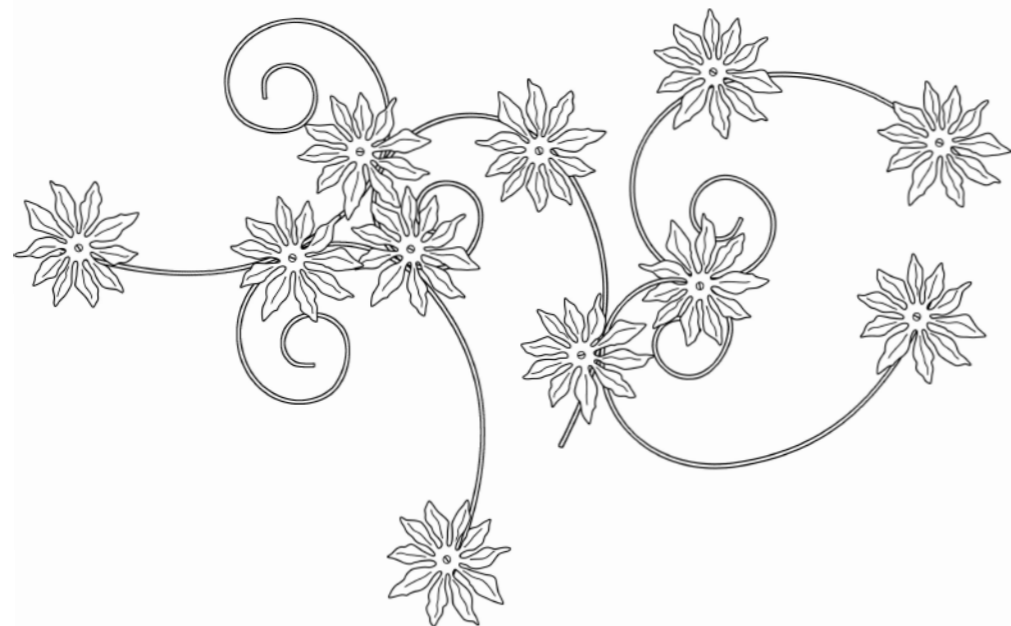

Design Pack WALL ART: ABSTRACT FLORAL PATTERN



DIFFICULTY RATING:

EASY	✓
STRAIGHTFORWARD	
MORE COMPLEX	

Design Pack: WALL ART: ABSTRACT FLORAL PATTERN - DESIGN SHEET

TEMPLATE No. 2

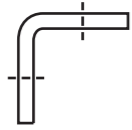
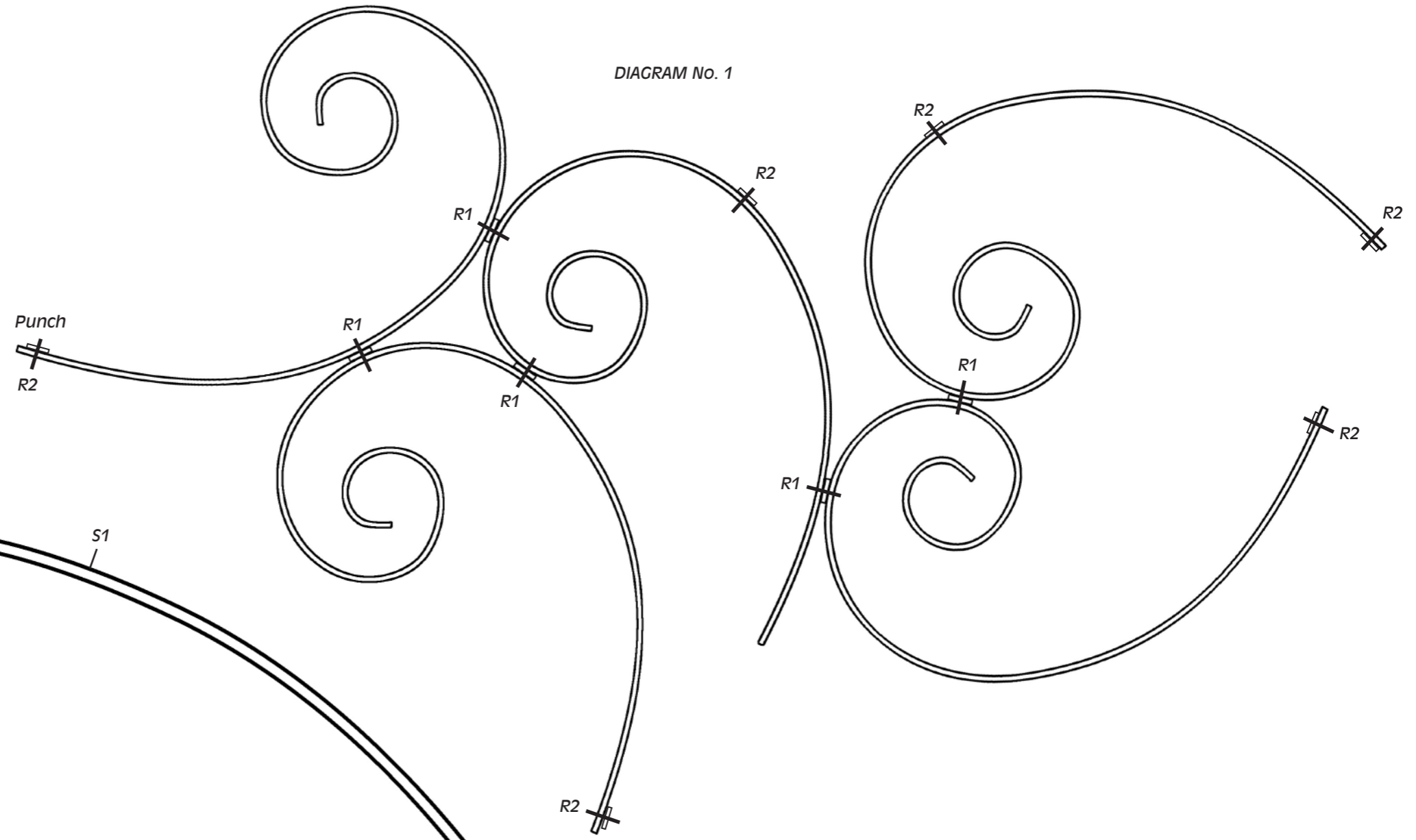
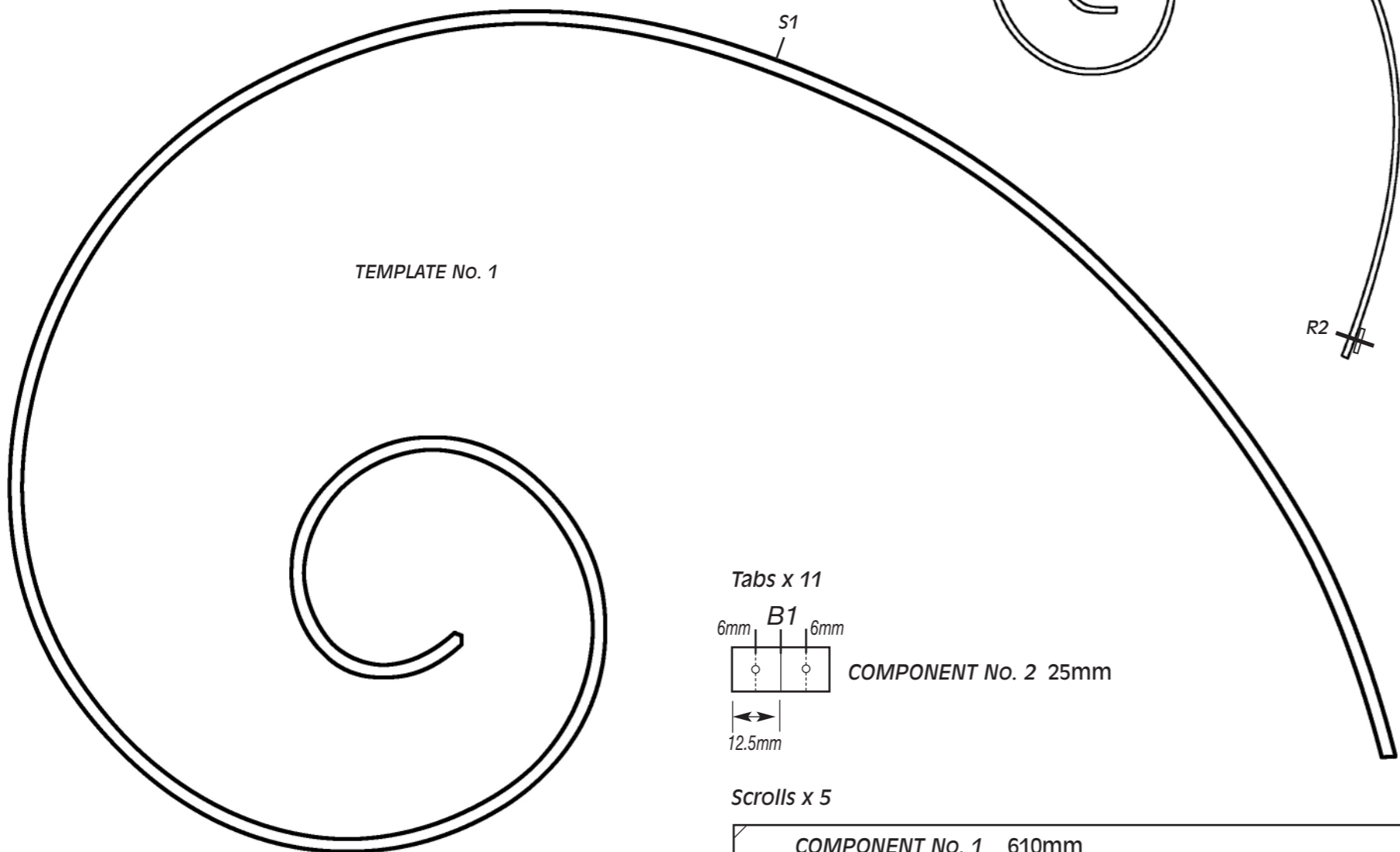

DIAGRAM No. 1



TEMPLATE No. 1



Tabs x 11

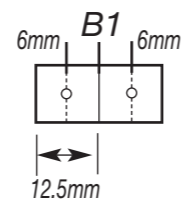

COMPONENT No. 2 25mm

Scrolls x 5

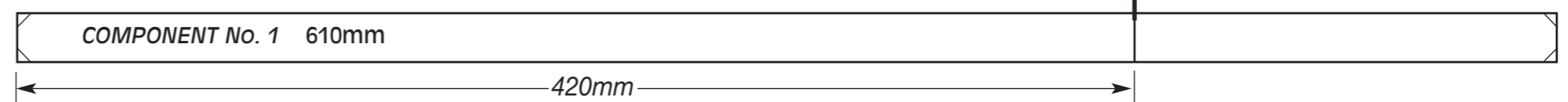

List of Materials Required:

- 5 x 920mm (3ft) Lengths of 12mm x 2mm Steel Strip [Re-Order Ref: MC034]
- 6mm x 3mm Nuts & Bolts [Re-Order Ref: MC058L]
- 10mm x 3mm Rivets [Re-Order Ref: MC052L]
- 8mm x 3mm Rivets [Re-Order Ref: MC051L]
- 11 x F33 10 Petal Flowers [Re-Order Ref: MC1401]

WALL ART: FLORAL BOUQUET

Tools Required to Make this Design:

Scrolling: Mk 1/2 Scroll Former (or Mk 2/2H or Mk 2/3)
 Punching: Practical or Master Punch/Shear (or XL5+ Power Bender fitted with 3mm punch block & pin)
 Riveting: Practical RBR
 Rolling: Practical or Master RBR (or XL5+ Power Bender - radius may need to be altered)
 Cutting: Practical or Master Punch/Shear (or XL5+ Power Bender)

1 Cutting

It is recommended with all steel lengths, you first remove any excess oil, grease or scale with a cloth or abrasive paper.

Take a length of 920mm (3') 10mm x 1.6mm steel, then, using a fine tip marker or pencil, mark at 550mm and cut (Component 5). Taking the offcut, mark at 350mm and cut (Component 2). Take another length of 920mm (3') 10mm x 1.6mm steel, mark out two 450mm lengths and cut (Components 3 & 6). N.B. marking the size on each length may help to identify which component is which later on.

Taking the final 920mm (3') 10mm x 1.6mm steel, mark and cut one length at 300mm (Component 4), one at 150mm (Component 7) and two at 100mm (Components 1 & 8). With all the cut lengths, trim all the corners for a better finish.

Finally, with the remaining steel from the 3rd final length, mark and cut eight 25mm 'tabs' (Component 9) - these will be used to attach the flowers.

2 Scrolling

Using the Mk 1/2 Former, take the 550mm length (Component 5), the two 450mm lengths (Components 3 & 6) and the 350mm length (Component 2) mark in 150mm from one end on each and scroll up to this mark S1 - i.e. to the end of the first segment on the Scroll Former.

3 Rolling

With the R/B/R Tool set up for rolling, take Component 1 and roll it to the approximate shape of that component as shown on the Design Sheet overleaf. Repeat for each component to the corresponding profile on the Design Sheet. Component 4 does not need rolling.

If you make a mistake, you can turn the metal round in the R/B/R and straighten the piece out and then re-roll it.

4 Bending

With the R/B/R Tool set up for bending, take the seven lengths of steel which need bending at the ends (the 100mm strip with the most curve (Component 8) does NOT need bending) and mark in 15mm from the opposite end to that which has been scrolled. Again using the Templates overleaf as a guide, bend each length to approx 140°, making sure you bend the right way.

Take the eight 'tabs' cut earlier in Section 1 and bend all at 90° in the centres - see Template No 2.

5 Punching

Taking the eight 'tabs' which have just been bent, punch approximately 6mm from each end. Use Component 9 overleaf as a guide.

Next, mark punch point 'H1' 7.5mm from the tip of each Stem as shown on the Design Sheet overleaf. Then punch at all these points.

6 Assembly

Lay all the components on top of the Template overleaf and mark the three main rivet points R1, R2, R3 on all the components and punch all these holes. Using a 6mm x 3mm rivet, rivet components together at R1. Use an 8mm x 3mm rivet to join Components 6, 7 & 8 at R2. Finally, rivet joint R3 to connect all components together using a 12mm x 3mm rivet.

Then rivet the eight Tabs to the holes H1 on each Stem using Diagram 2 as a guide to fix the Tab onto the correct side of the bend.

Attach the flowers using the 6mm x 3mm nuts & bolts provided.

7 Finishing

The finished item can now be painted in a wide variety of finishes (smooth, satin, hammer and metallic) either by aerosol or by brush application. Powder coating and plastic dip finishes can also be applied but these type of finishes are more for commercial/industrial scale finishing.

However, even with aerosol or paint finish you can make your finished item look professional. In this case we used paints from the Plasti-kote and Hammerite ranges - available from most DIY and Painting/Decorating outlets. For best results, always follow instructions on the tin and make sure the metal is free of all scale, dirt, grease or rust.

Note - for more interesting effects, you can also use Letraset Promarker pens to achieve a wide range of colours & effects on the flower attachments.

If you wish you can add one of our decorative stampings (not provided) to mask the join or you can use some ribbon (not provided) as shown on the front cover to add a nice finishing touch.

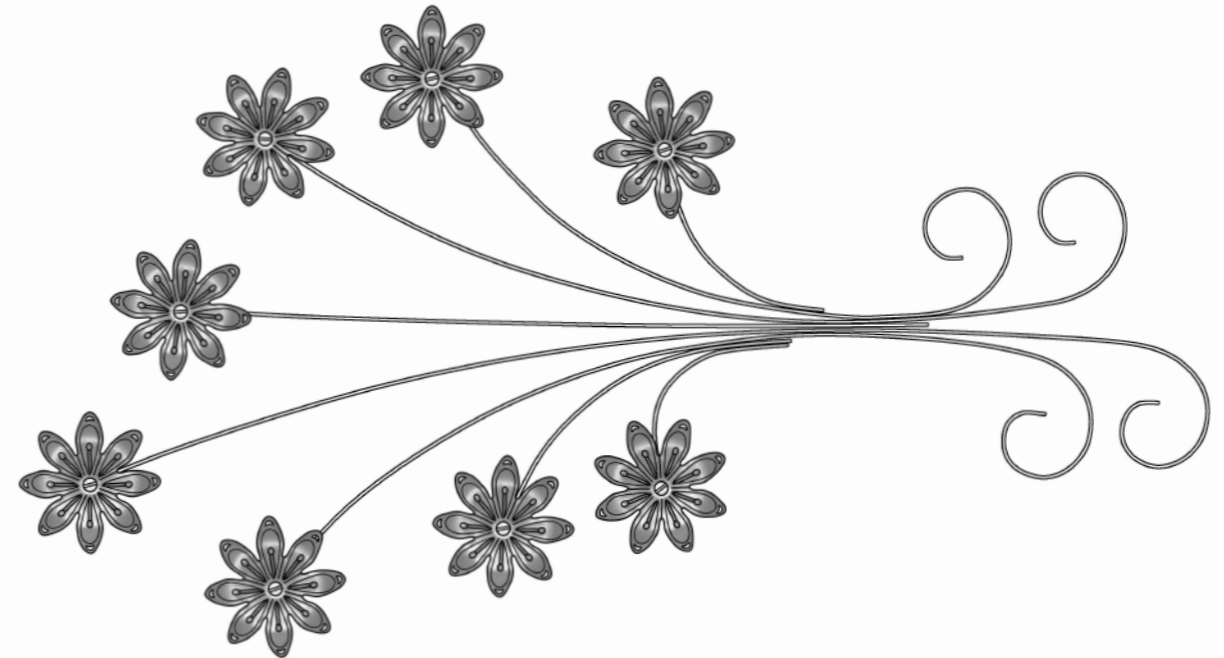

metalcraft™

Design Pack WALL ART: FLORAL BOUQUET

DIFFICULTY RATING:

EASY	✓
STRAIGHTFORWARD	
MORE COMPLEX	

Design Pack: WALL ART: FLORAL BOUQUET - DESIGN SHEET

List of Materials Required:

- 3 x 920mm (3ft) Lengths of 10mm x 1.6mm Steel Strip [Re-Order Ref: MC031]
- 8 x F30 8 Petal Flowers [Re-Order Ref: MC1400]
- 12mm x 3mm Rivets [Re-Order Ref: MC053L]
- 8mm x 3mm Rivets [Re-Order Ref: MC051L]
- 6mm x 3mm Rivets [Re-Order Ref: MC050L]
- 6mm x 3mm Nuts & Bolts [Re-Order Ref: MC058L]

Diagram 2

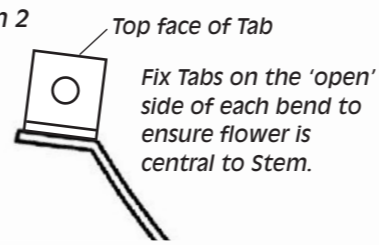

Scroll all these four 'stems' to the end of the first segment on the Mk 1/2 Former - approx 150mm

