

## J & CR WOOD

66 CLOUGH ROAD , HULL, HU5 1SR

TEL: 01482 345067, FAX: 01482 441141

Email: [info@jandcrwood.co.uk](mailto:info@jandcrwood.co.uk) ,

[www.metal-craft.co.uk](http://www.metal-craft.co.uk)

Copyright of J&CR Wood 2016. All rights reserved.

No part of this publication may be reproduced by  
whatever means without prior written permission of  
J&CR Wood



[www.twitter.com/metalcraftuk](http://www.twitter.com/metalcraftuk)



[www.facebook.com/metalcraftuk](http://www.facebook.com/metalcraftuk)



[www.pinterest.com/metalcrafttools](http://www.pinterest.com/metalcrafttools)



[www.youtube.com/metalcraftuk](http://www.youtube.com/metalcraftuk)

# OPERATING INSTRUCTIONS

**metalcraft**™

**PRACTICAL-PUNCH AND SHEAR**

**J&CR**  
WOOD



[www.metal-craft.co.uk](http://www.metal-craft.co.uk)

# PRACTICAL-PUNCH AND SHEAR

1

Fix the Punch and Shear tool firmly to the work bench with screws .

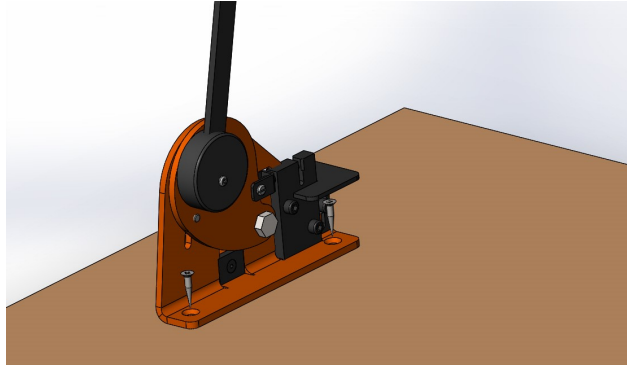

2

## MEASURING DEVICE (OPTIONAL)

### ASSEMBLY FIXING AND SET UP

(a) Assemble the tape measuring device by first hammering the spigot (572b) half way into the dimpled end of one of the measuring bars (572a), then hammer the remaining measuring bar (572a) at the dimpled end into the other half of the spigot (572b).

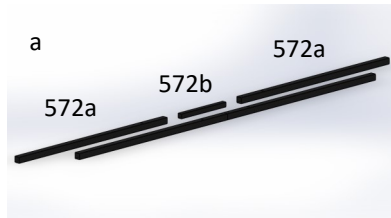

(b) Attach the locator bracket (1788) to the bench towards the back of the P/P/SH with screws (not supplied). Offer up the assembled measuring bar into the slot of 1788 and make sure it sits tight up against the body, also making sure the measuring bar is at a right angle to the P/P/SH.

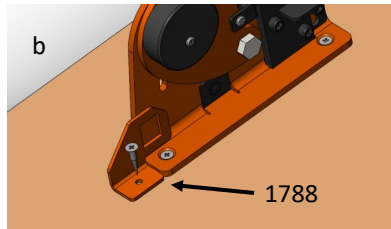

(c) Attach the bench mounting bracket (568) using screws (not supplied) to the bench, then line up the measuring bar so that the back of 568 sits flush with the end of the measuring bar (572). Once the two brackets have been fitted remove the measuring bar and feed the tape and holder (1786\*) over the measuring bar (572) and then place the end of the tape over the measuring bar and through (1788) and then up against the P/P/SH body (d), lock the measuring bar in place by tightening (569\*) on part (568).

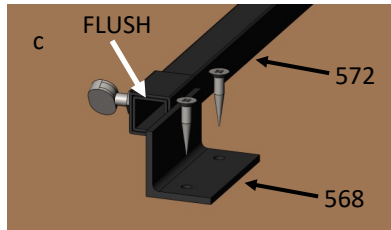

\* See exploded view of Tape Measuring device on page 4.

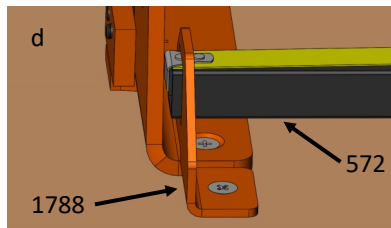

4

## PUNCHING without the use of the Measuring Bar.

Mark the edge of the metal bar where the hole is to be punched. Place the metal bar so that the mark is in the centre of the punch block then push the handle back beyond the vertical position so that the punch pin retracts into the punch block body thereby leaving the punch block clear. Place the bar into the slot making sure that the mark you made is on the edge and in the centre of the punch block. Pull the handle down towards you to punch the bar, remembering to **always support the bar you are punching-keep it level with the punch block so as not to break the punch pin.**

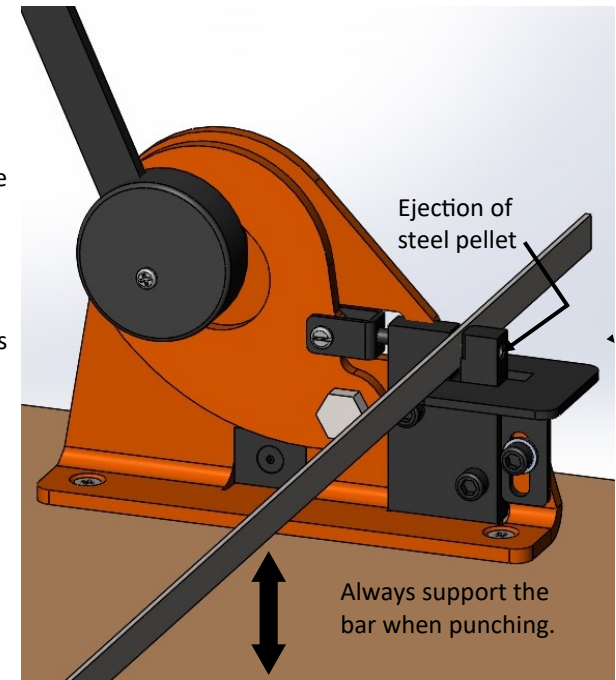

**WARNING:** During punching steel a pellet may be ejected at high speed from the punch block. Eye protection is recommended.

4

## ADJUSTABLE PLATFORM

This mechanism can be fixed at different heights to enable the machine to punch holes at consistent distances from the edge of the metal bar, or in the centres of various widths of bar.

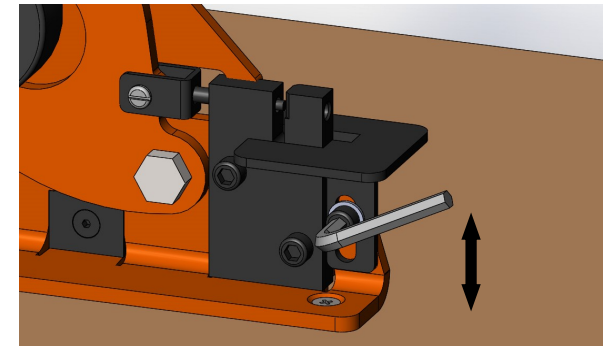

Due to our policy of continual development and improvement the company reserves the right to modify Metalcraft tools without prior notification.

### 3 CUTTING METAL BAR

First start by setting the tape measuring holder (1786) to the correct length by undoing the thumb screw (569) and locking in place. If your Practical Punch and Shear does not have a tape measuring device simply mark the metal bar to the desired length. Next open the gap between the blades by pulling the lever forward. Insert the metal bar into the guillotine (with the mark at the edge of the blade). Push the handle back until the blade closes and shears the bar. Trim the corners of the steel for a more professional finish (a)

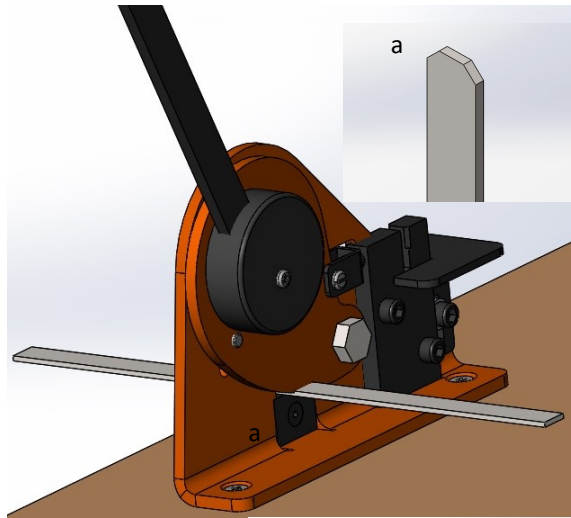

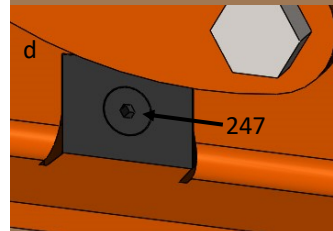
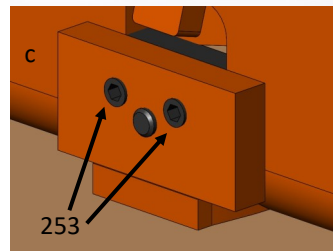
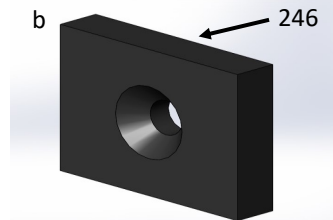

### CHANGING THE SMALL BLADE

The small blade 246 has 4 cutting edges (b) and can be rotated when one edge wears. To change the small blade, bring the large blade up then **loosen** the two grub screws 253 (c), next remove the screw 247 on opposite side (d) and then rotate the blade and place back in the slot. Tighten the screw (247) then back this off approximately 1 full rotation. Bring the large blade down then tighten both grub screws 253 this will push the small blade up against the large blade. Tighten 247 there should be no gap between the two blades if there is keep the large blade in the down position, loosen 253 **then** loosen 247 slightly, next tighten up both grub screws 253. If there is still a gap repeat this process.



**SPECIFICATION TABLE**      **MAXIMUM SIZE MATERIAL**

OPERATION			
CUT	5mm	5mm	20mm x 3mm
PUNCH	-	-	3mm

### IMPORTANT NOTES:

- 1) These sizes are for hot rolled black mild steel bar and annealed bright mild steel bar.
- 2) Ensure all moving parts are regularly lubricated and all bolts kept tightened.
- 3) Working beyond the capacities stated above or materials with greater strength or hardness will reduce the operational life of the machine.
- 4) Please keep these instructions in a safe place for any future reference to the parts diagrams.

The Practical Punch and Shear Tape Measuring Device will help to achieve consistent cut lengths of steel every time and also produce accurate distances between your punched holes.

### SET THE LENGTH TO CUT

(e) Undo the thumb screw (569) on the tape holder, this will enable the carriage to move up and down the bar, set the desired measurement taking note of what the tape measures reads (f). Once locked off this will cut the bars at this length. Simply bring the handle back to feed the bar through the blades and then up against the stop (g), then move the handle in the opposite direction to cut the steel always making sure that the steel is pushed up against the stop.

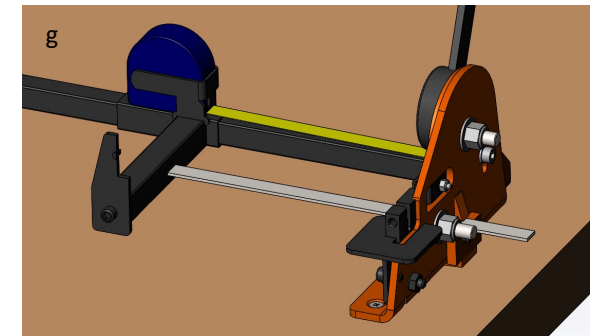
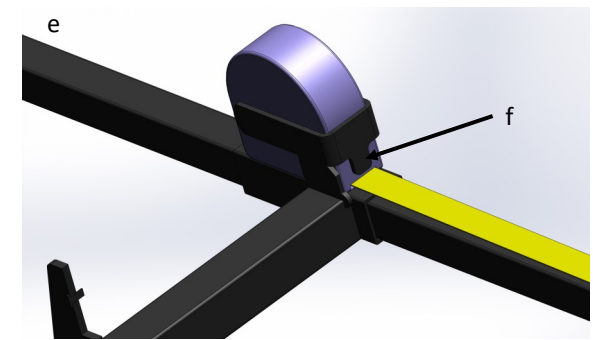

### SET THE DISTANCE FROM THE CENTRE OF THE PUNCHED HOLE TO THE END OF THE BAR

To set your punched hole move the carriage to the desired length and lock off using (569). Once your measurement is chosen bring the handle back to feed the bar (with the platform set to the correct size of steel) through the punch block and up against the punch stop (h). Keeping the bar tight against the stop move the handle in the opposite direction and punch the hole.

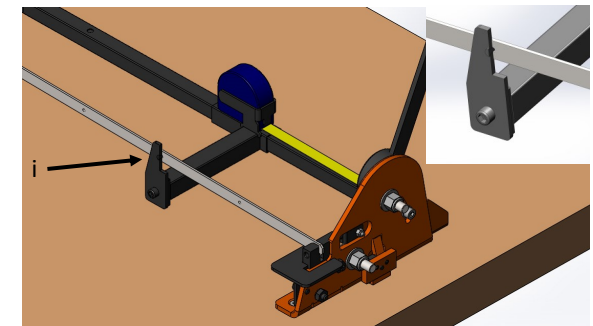
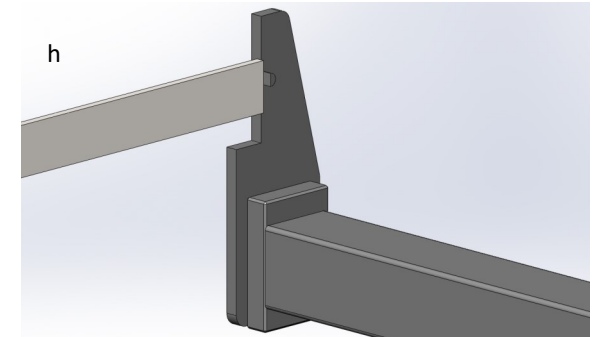

### SET THE DISTANCE BETWEEN PUNCHED HOLES

Set the tape measure to the desired length lock off then place the already punched hole over the location pin (i) and punch the hole.

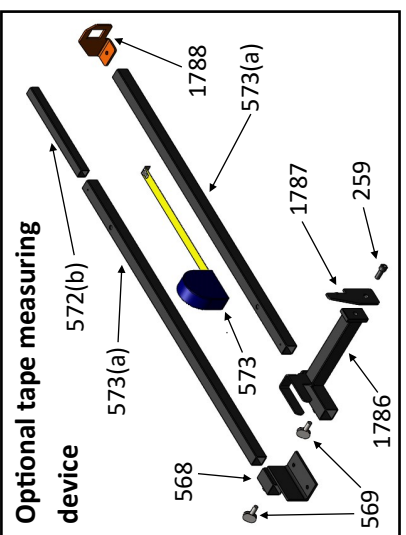
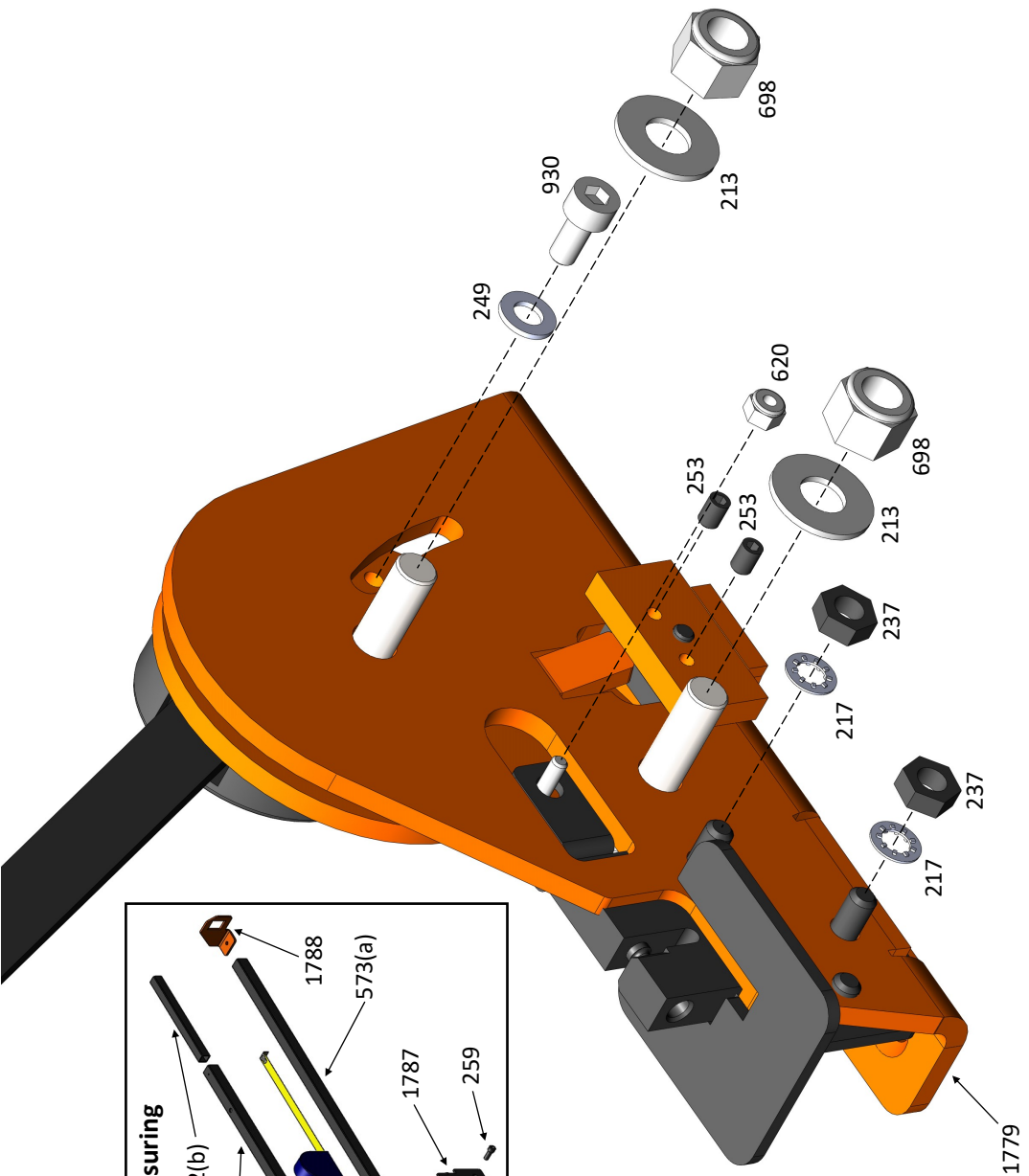

**Optional tape measuring device**

**ATTENTION**  
\*These parts are not covered by the warranty

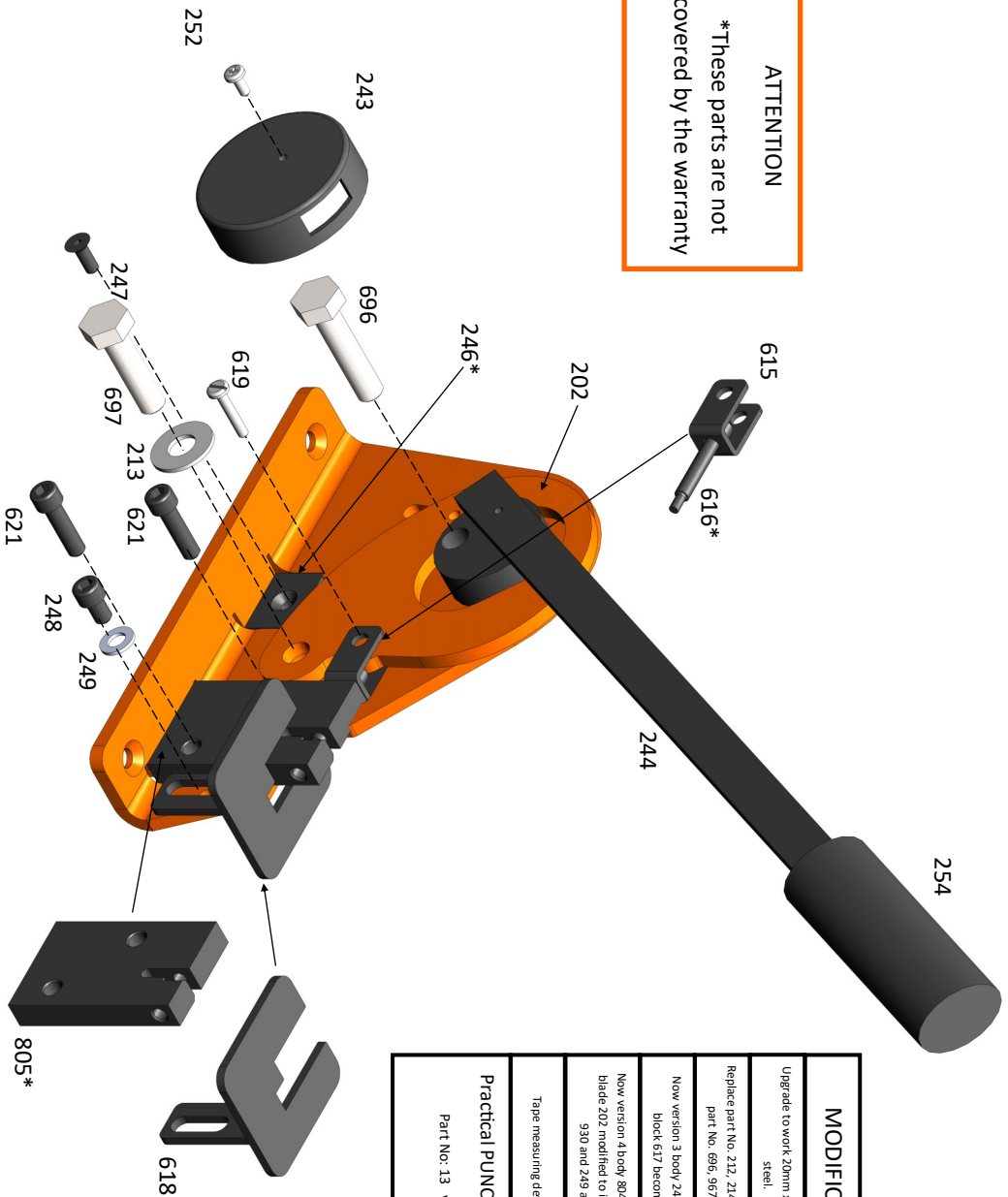

MODIFICATIONS	
09/98	Upgrade to work 20mm x 3mm hot-rolled steel.
01/01	Replace part No. 212, 214, 215 & 245 with part No. 696, 967 and 698.
03/02	Now version 3 body 242 becomes 804 block 617 becomes 805.
09/15	Now version 4 body 804 becomes 1779 blade 202 modified to improve cutting 930 and 249 added.
08/16	Tape measuring device added.

**Practical PUNCH AND SHEAR**  
Part No. 13 version No 3