



Design Notes

Poinsettia Stand

Difficulty Rating:

Easy	
Straight forward	YES
More complex	

Please note:

These Design Notes are for our regular metalcrafters who are familiar with our more comprehensive Design Pack instruction sheets and who are ready to progress on to new projects where briefer outline instructions are sufficient. The dimensions in the diagram(s) shown overleaf are approximate and for guidance only. Where bend angles, rolling radii or other information are not specified it is assumed that the reader is experienced enough with Metalcraft tools to be able to work these out for themselves from the drawings provided.

Tools required to make this design

Punching	Practical Punch/Shear Tool (PPS) or Master Punch/Shear or XL5+ Power Bender fitted with 3mm Punch Block & Pins.	YES
Cutting	Practical Punch/Shear Tool (PPS) or Master Punch/Shear Tool or XL+ Power Bender Tool	YES
Riveting	Practical Riveting Bending and Rolling Tool (PRBR)	YES
Bending	Practical Riveting Bending and Rolling Tool (PRBR)	YES
Rolling	Practical Riveting Bending and Rolling Tool (PRBR)	YES
Scrolling	Mk 1/2 Scroll Former	YES

We recommend that before starting you wipe all steel bars down so that they are free of grease, scale or dirt. After cutting any component, we also recommend that you trim the corners for a neater finish, if preferred, unless these instructions tell you otherwise. Use a fine tip marker pen, pencil or scribe for marking hole, bend, scroll, roll points on the bars.



66 CLOUGH ROAD, HULL HU5 1SR • TEL: 01482 345067 • FAX: 01482 441141
email: info@jandcwood.co.uk • www.metal-craft.co.uk

Issue 1, November 2015

Copyright of J&C Wood 2014. All rights reserved. No part of this publication may be reproduced by whatever means without prior written permission of J&C Wood



INSTRUCTIONS: POINSETTIA STAND

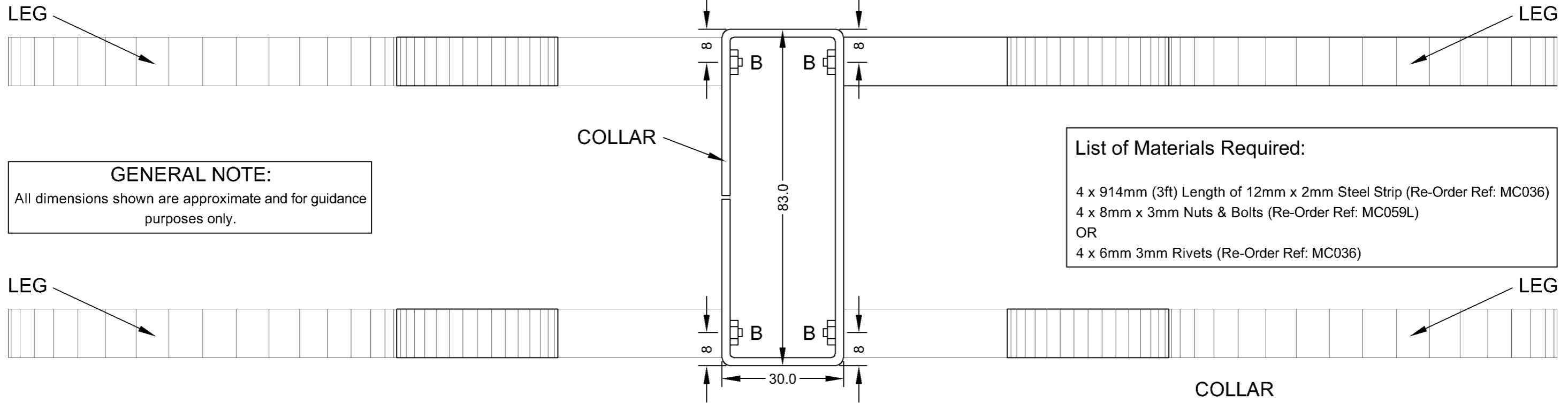

TOP VIEW ACTUAL SIZE

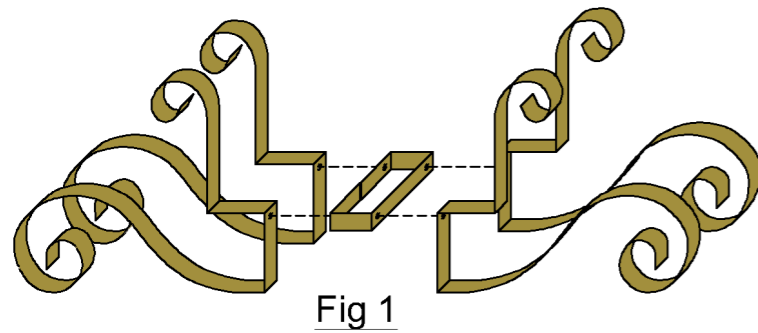

COLLAR

12 x 2mm Strip-226mm long.
Bend strip as shown to form rectangular collar.

LEGS (4 No. req'd)

12 x 2mm Strip-620mm long.
Mark each strip 350mm from one end. This section of the strip is the Leg end. Scroll both ends to 120mm (end of first segment). Note the scrolls are on the opposite faces of the steel strip. Roll both faces of the 350mm section (the Leg end) as shown to form the Leg. Bend the remainder of strip as shown to form the plant holder. Use the Side View as guide.

ASSEMBLY

Punch and bolt at connections designated with a "B", or Rivet components together, twisting each leg in line with collar to enable both components to fit between riveting posts. Once riveted rotate leg through 90°. See also Fig 1.

SIDE VIEW ACTUAL SIZE

